

FG21201

FIAMM

FIAMM Sealed Power

FG series

FG21201 is a general purpose application battery. Within the FG range Fiamm offer 6V and 12V monoblocs at various amp hour capacities enable the right battery selection for each requirement. FIAMM Sealed Power is a Manufacturer of VRLA batteries; and is supported by a dedicated sales network with market knowledge and experience of small sealed lead acid battery applications.

**12 Volt
12 Ah**



Features

Nominal Voltage	12 Volt
Nominal Capacity	12 Ah at 20 hours rate to 1.75 Vpc at 25 °C
Float charging voltage	13.50 - 13.80 V/bloc at 25 °C
Boost charge voltage	14.40 - 15.00 V/bloc at 25 °C
Float voltage compensation	-18mV/°C
Maximum charging current	3 A
Case	ABS with HB flammability rate (according UL94)
Internal resistance	30 mΩ in full charged condition
Weight	3.75 kg
Dimensions	L x W x H (TH): 151 x 98 x 94 (99)
Operative temperature range	-20 °C to 50 °C

Storage

As batteries lose part of their capacity, during storage, due to self discharge. Fiamm Sealed Power recommends FG range of batteries can be stored for 6 months at an ambient temperature of 20 and 25 °C (see attached graph on reverse). Longer storage requires a recharge. This should be carried out in line with Fiamm Sealed Power recommended method; 2.4 V/cell for no longer than 24 hours at 20 °C

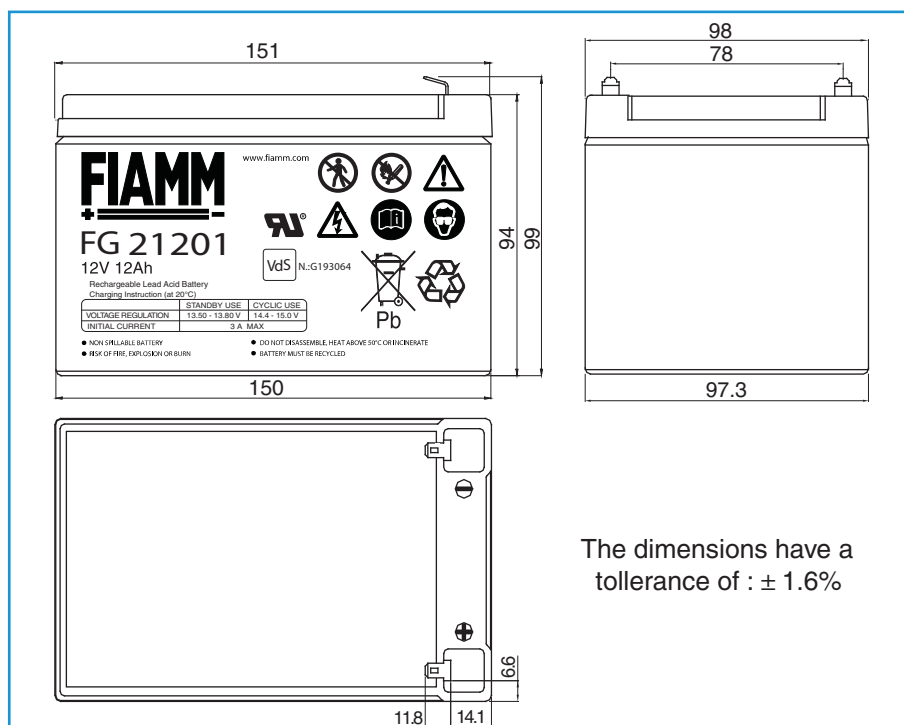

Faston 4.8 mm

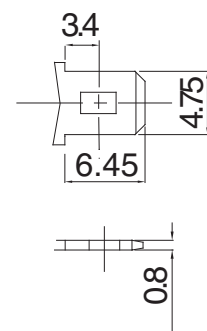

Capacity loss during storage at various temperatures

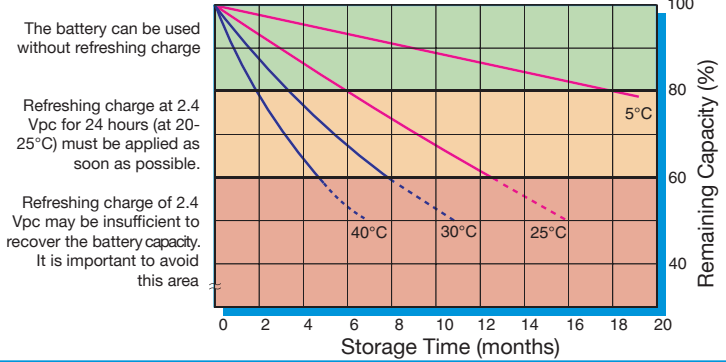

Battery Voltage and Charge Time for Standby Use (at 25°C)

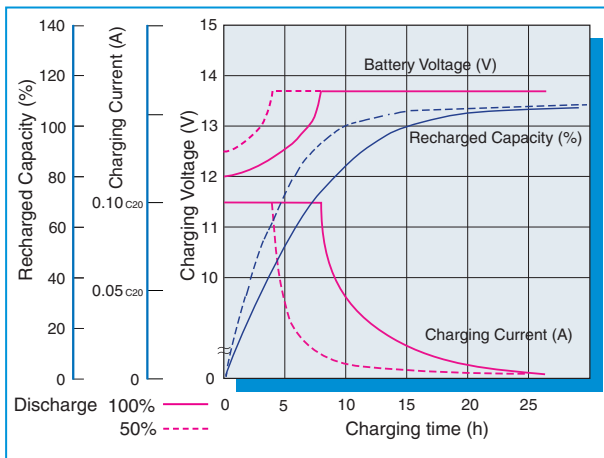

Discharge curves at different current / final voltage (at 25°C)

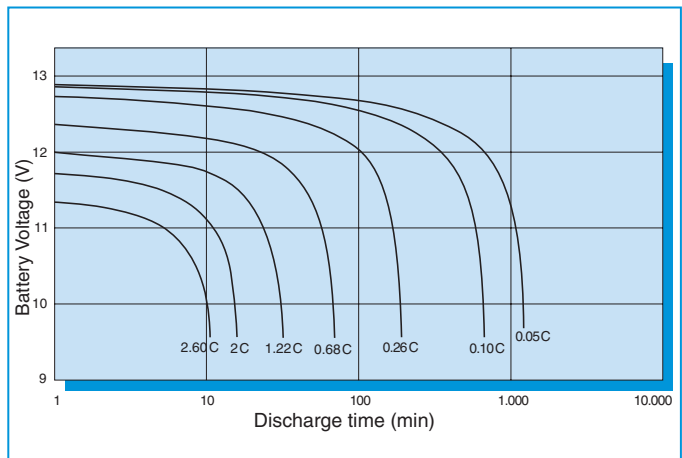

Constant Power discharge table (Watts per bloc) at 25 °C

end voltage	5 min	10 min	15 min	20 min	30 min	45 min	1 h	2 h	3 h	5 h	10 h	20 h
9.60 V	391	284	221	182	138	104	84.3	49.0	36.0	24.1	13.5	7.31
9.90 V	382	279	218	179	137	103	84.0	48.6	35.8	24.0	13.4	7.29
10.02 V	377	275	217	178	136	102	83.4	48.4	35.6	23.9	13.3	7.29
10.20 V	373	273	215	177	135	102	82.9	48.3	35.5	23.9	13.3	7.28
10.50 V	359	266	213	176	134	101	81.8	47.8	35.2	23.8	13.2	7.26
10.80 V	330	246	196	165	127	96.5	78.6	46.4	34.3	23.3	13.0	7.16

Constant Current discharge table (Amperes) at 25 °C

end voltage	5 min	10 min	15 min	20 min	30 min	45 min	1 h	2 h	3 h	5 h	10 h	20 h
9.60 V	39.2	27.7	21.1	17.0	12.7	9.37	7.50	4.30	3.14	2.09	1.16	0.63
9.90 V	38.1	27.0	20.7	16.7	12.5	9.23	7.44	4.25	3.10	2.07	1.15	0.62
10.02 V	37.1	26.4	20.4	16.6	12.3	9.12	7.34	4.21	3.07	2.05	1.14	0.62
10.20 V	35.7	25.7	20.1	16.4	12.2	9.02	7.24	4.17	3.04	2.04	1.13	0.62
10.50 V	34.0	24.5	19.1	15.7	11.8	8.79	7.07	4.08	2.98	2.00	1.11	0.60
10.80 V	31.5	23.0	17.8	14.8	11.2	8.39	6.78	3.96	2.91	1.97	1.09	0.60